

ESTWELD®

ESTWELD®



Ningbo Hi-tech Yuanchuang Technology Co.,Ltd

No.69 Chuangfu Road,Xiaogang Industrial
Park - 315 803,Ningbo,China
Tel : +86-574-86196992
Fax : +86-574-86196753
E-mail : ceo@ycest.com
Web : www.ycest.com



NINGBO HI-TECH YUANCHUANG TECHNOLOGY CO.,LTD ,was established in 2008.We have been the most leading and specializes in the manufacture of exothermic welding, grounding and lightning protection products.Furthermore,the company is also a pioneer of novel grounding materials in China. We has woned five patents of invention and ten patents for utility models and three appearance patents.

At present, the company's products have been widely applied in industries such as Electric Power, Railway, Industrial, Petrochemical, Communication, and other Public and Private Utilities.The company has been assessed and reviewed as a qualified supplier by many national large construction companies.

The enterprise has a full range of production and R&D equipment, is complete in department setting and strong in technology strength. It has several experienced R&D technical engineer and many lightning protection specialists nationwide to provide comprehensive technical support. With reputation as the life of enterprise, the company carries out strict and scientific production and management, acts at a rapid and flexible response speed to ensure the sustainable development of product quality and technology, and strictly implements the ISO 9001:2008 quality management system.

We will wholeheartedly provide top-quality products and service for customers at home and abroad and wish to seek common development in multi-directional and multi-layer cooperation!



PLANT APPROVALS



PRODUCT APPROVAL



The molecular bond that eliminates connections by forming an electrically perfect bond unaffected by corrosion

Connections are the weak point of all electrical circuits and especially earthing circuits subjected to aging and corrosion. The capacity of an earthing circuit to protect the safety of personnel depends on the quality of the connections made.

Welding Metal

- ◆ High temperature reaction can molten large cross-section cable
- ◆ No toxic and heavy metal
- ◆ No slag and porosity
- ◆ Smooth reaction
- ◆ Low resistance

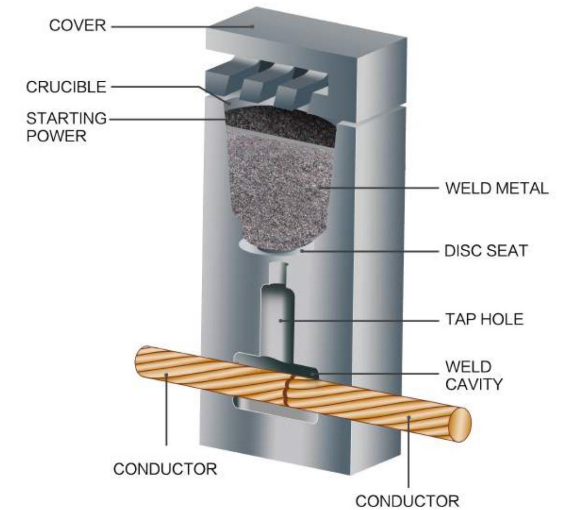

ESTWELD® - The Molecular Bond

The ESTWELD® process provides a way to produce copper to copper, copper to steel molecular bonds with no external energy or heat source. The principle consists of bringing together a welding materials and ignition agent in a suitable graphite mould. The reduction of copper oxide by aluminium produces molten copper and aluminium oxide slag at extremely high temperatures. The shape of the mould, its dimensions, and the size of the welding material, are all dependent on the items to be welded.

Installation Is Easy

1. Position cleaned conductors in mold after making sure mold is dry, by pre-heating or making a test joint.
2. Place metal disc in bottom of mold crucible.
3. Dump weld powder into crucible.
4. Sprinkle the starting powder over the weld powder and onto the lip of the mold. Close the cover.
5. Ignite the starting powder with the Flint Ignitor.
6. Remove weld and clean mold before making next connection.



ESTWELD® WELD POWDER

- ESTWELD® weld powder is a mixture of copper oxide and aluminium, packaged by size in individual plastic tubes or bags.
- Each tube contains the starting material in the lid, with the weld powder in the tube.
- Each bag contains the individually packed starting material with weld powder in the vacuum aluminum foil bag.
- These containers are packaged in plastic boxes with the corresponding metal disks. Each weld uses one disk.
- These materials are not explosive and not subject to spontaneous ignition.



ESTWELD® SAFE connections offer all the benefits of SAFE conventional ESTWELD SAFE connections:

- Current carrying capacity equal to or greater than that of the conductor
- Withstand repeated fault currents without failing during operation
- Permanent, molecular bond that will not loosen or corrode, resulting in a connection with a lifetime equal to that of the installation
- Join copper to copper, copper to galvanized or plain steel, copper to copper clad steel, copper to bronze/ brass/stainless steel, steel to steel, etc.
- No external power or heat source required
- Quality Assurance Inspection is easy and visual
- Minimal installation training required
- Exceed requirements of "UL for Qualifying Permanent Connections Used In Substation Grounding"

Continuing the tradition of technical leadership, ESTWELD® SAFE was developed as a simplified method of performing exothermically welded electrical connections. This trusted system now features a new ESTWELD SAFE cup design for the integrated welding material package which has streamlined the installation process by eliminating ignition materials.

The tamper proof, integrated welding material package consists of a copper cup containing ESTWELD® SAFE patented welding material alloys and an ignition source. This newly shaped welding material package is designed for use in all standard ESTWELD® SAFE molds. Once placed in the ESTWELD® SAFE mold, the welding material is electronically ignited using a simple battery-powered control unit with a six-foot lead.

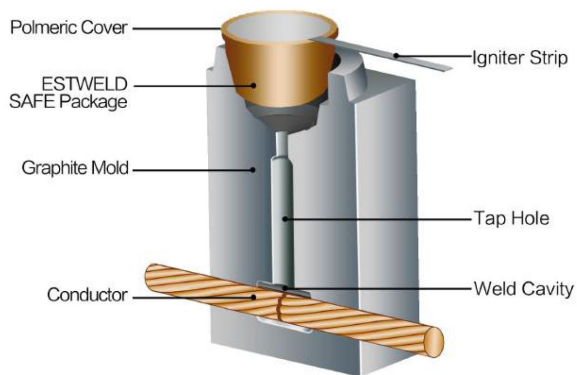

ESTWELD® SAFE

Feature	Benefits
Integrated Welding Material Package	<ul style="list-style-type: none"> • Simplifies training and set up • Saves labor • Simplifies cleaning
Electronic Control Unit	<ul style="list-style-type: none"> • No starting material required • Easy ignition
Replaceable Six foot or lengthenable Control Unit Lead	<ul style="list-style-type: none"> • Increased flexibility in hard to reach areas
Smoke Filter Mold	<ul style="list-style-type: none"> • Prevent sparks and produce minimal smoke • Can be used in a specific place

The ESTWELD® SAFE system:

- Consists of a tamper proof, disposable moisture-resistant welding material cup. The welding material, disk and ignition source are incorporated into the self-contained package
- Long shelf life
- Completes welds at distances of up to 6 ft/1.8 meters (can be extended)
- Requires minimum components – no starting material, no disks, no flint igniters
- Easy to handle, store and transport – by air, land or sea in unlimited quantities
- Reduces installation time by 20%
- Has safety-certified electronic igniter is designed for 500 connections with one set of 8 standard AA batteries (included) – requiring no special batteries or chargers
- Designed for use in standard ESTWELD® SAFE molds

Installation Is Easy

4 Simple Steps For Permanently Welded Electrical Connections



Insert ESTWELD® SAFE package into mold



Attach control unit termination clip to igniter strip



Press and hold control unit switch and wait for the ignition

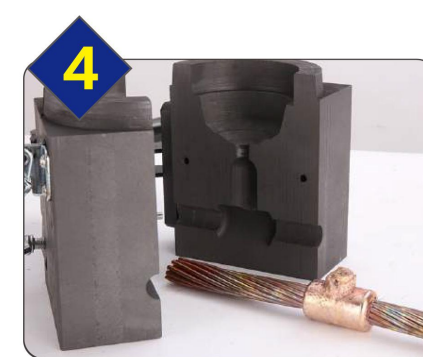

Open the mold and remove the finished connections.

BETTER THAN MECHANICAL CONNECTIONS, LESS LABOR AND COST

ESTWELD® SAFE high-voltage welds are permanent molecular bonds that cannot loosen or deteriorate, no maintenance is required and no resistance increase over time, so there is a continuous optimal electrical path. This makes ESTWELD® SAFE connections superior to traditional compression or mechanical connections that provide only surface contact between conductors and a less-than-perfect current path. In addition, ESTWELD® SAFE high-voltage welding system is easier to use and lower in labor cost, since you don't need a certified welder. Full on site training can be provided by ESTWELD® SAFE Engineers.

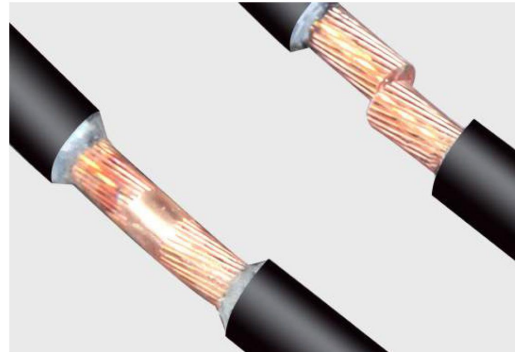
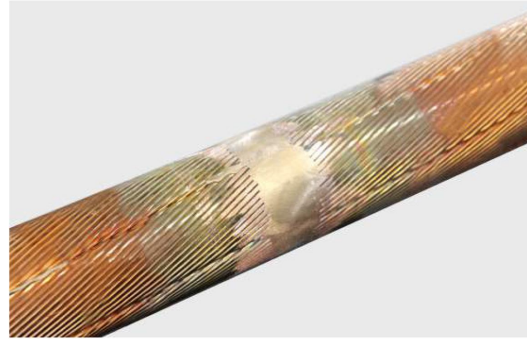

A LOW EMISSION PROCESS

ESTWELD® SAFE high-voltage welding set-up uses a unique smoke filter system which prevents sparks and produces minimal smoke, but also reduces dust and other emissions to an acceptable level for exposures, even if used in unventilated small rooms and cable tunnels.

ESTWELD® SAFE welding is a reliable method of quickly making electrical connections.

OPTIMUM STANDARDIZATION:

Welding equipment (crucible, smokefilter body, frames, etc.) is standardized and can be used on all connections. Only different molds and different types of welding material are needed for Copper welds.

ESTWELD® SAFE connections give you a single process for making all cable-to-cable, splices and terminations connections.

The welding material contains copper and aluminum oxide as well as additional ingredients.

The ignitor starts an exothermic reaction inside the crucible, producing the molten copper or molten aluminum. The molten material then flows from the crucible into the mold, welding the ends of the conductors to create the molecular bond.



ESTWELD® SAFE High-Voltage System Advantages:

- ESTWELD® SAFE high-voltage welding system can weld different sections copper cables.
- ESTWELD® SAFE connections can be made easily with minimal training.
- ESTWELD® SAFE weld is small –handling is simple after welding
- Specially designed weld profile for high-voltage applications.
- No external power or heat source required. Has a current carrying capacity equal to that of the conductor.
- Permanent molecular bond will not deteriorate with age, cannot loosen or corrode.
- Will withstand repeated faults, is made with lightweight equipment, has low labor cost and is time saving on jobsites.

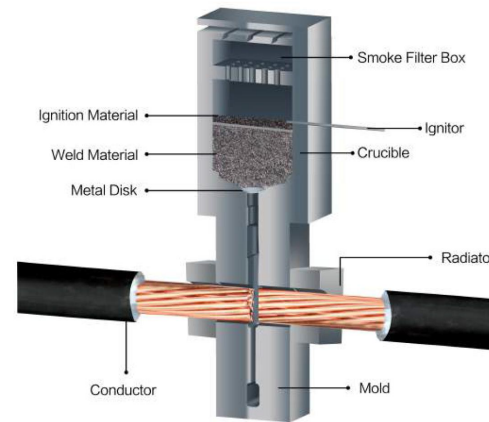

Strength results

In laboratory tests, the tensile strength of ESTWELD® SAFE high-voltage cable connections proved to have overall strong results. The tests show on average that the ESTWELD® SAFE connection provides about 75% tensile strength compared to the cable by itself. Test results vary between approx. 60% up to 90% tensile strength, whereby the breaking point is annealed cable at the edge of the ESTWELD® SAFE weld.

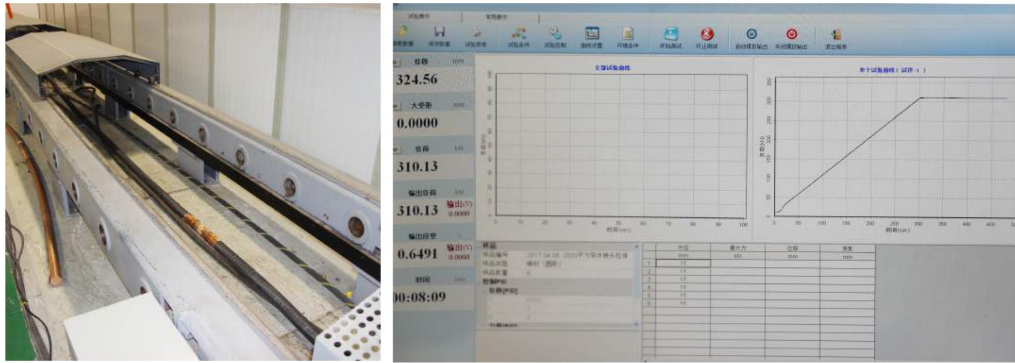

Performance results

Like ESTWELD® SAFE connections, their permanent low resistivity provides a current-carrying capacity that's greater than the conductors.



Railway Electrical Protection

The consequences of an unexpected lightning strike or power surge can be catastrophic for a facility:

- Risk to personnel
- Critical equipment may be damaged, or destroyed
- Data can be corrupted
- The costs of operational downtime and lost revenue can be very substantial

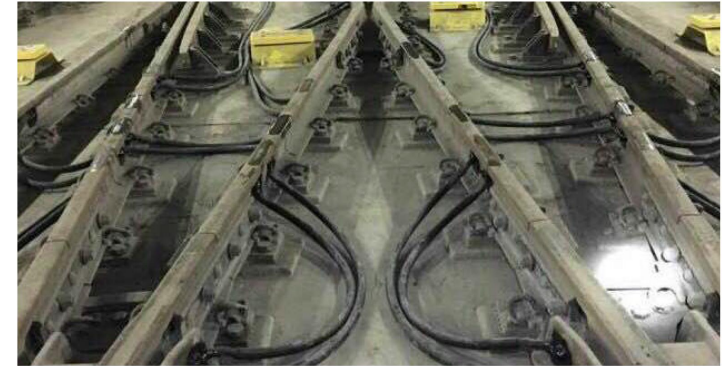

As the railway industry becomes more dependent on increasingly sensitive equipment, proper protection from lightning and dangerous over-voltage transients is necessary.

After a long period of research, testing and product development, ESTWELD® has acknowledged that no single technology can totally eliminate vulnerability to lightning and power surges.

Connections to the Rail

ESTWELD® is a molecular bond which-when properly applied-cannot loosen, resists corrosion and produces a maintenance-free electrical connection.

Railway signaling is a system used to control traffic safely, essentially to prevent trains from colliding.

Exothermic welding is one of the most popular methods of railway signaling bond. In welding process, the martensite is formed by rapid cooling, quenching, of austenite which traps carbon atoms that do not have enough time to diffuse out of the crystal structure. When viewed in cross-section, the lenticular (lens-shaped) crystal grains appear acicular (needle-shaped). Martensite affects the rail with increasing risk of cracking and brittle.



Macrostructure of a cross-section of exothermic welding for railway signaling bond

EST® Ground Enhancement Material

A superior conductive material that solves the toughest grounding problems.

- Improves grounding effectiveness regardless of soil conditions.
- Can use where ground rods cannot be driven or where limited land area makes adequate grounding difficult with conventional methods.
- Unmatched for reducing earthing resistance and maintaining low resistance permanently.
- No other material equals GEM in providing high conductivity for the life of the grounding system.



EST® Ground Rods

- Perfect copper molecules and steel rods continue to combine: by the solid cold pumping steel rods. First coated with a layer of nickel, and then plated with nickel on the nickel layer. Because nickel and steel have good bonding properties, so as to ensure the perfect combination of copper and steel core.
- High strength, suitable for deep drilling, which easily into the ground, copper does not break, do not fall off.
- Due to the strong corrosion resistance of copper, EST® copper plated steel rods also have good corrosion resistance.
- Product life expectancy is expected to exceed 40 years.
- Construction is very convenient, manual or use of related machinery construction.

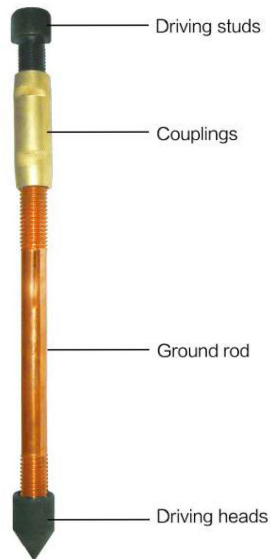

Patent Certificate



